





NEW HOLLAND LM5000

LM5040 | LM5060 | LM5080



- 3 MORE PRODUCTIVITY AND POWER. 
- 4 SUPERIOR VISIBILITY AND COMFORT. 
- 5 PROVEN QUALITY AND RELIABILITY. 
- 6 LESS MAINTENANCE, MORE WORK. 
- 6 SPECIFICATIONS.

NEW HOLLAND LM5000. ALL NEW DESIGN.

The new New Holland LM5000 series are powerful, stable and comfortable 120hp(CV) telehandlers with a choice of models to suit the specific needs of a diverse range of end users. The range offers all-round visibility from the 360° Vision cab, a New Holland patented driveline and corner-to-corner wheelbase chassis with an exceptionally strong boom system. For added refinement, LM5000 telehandlers benefit from an in line engine concept with an industry unique three-point mounting for vibration damping of the engine and transmission. The side-engine LM5000 design offers outstanding levels of performance, exceptional stability and superb refinement and is further complimented with a specification choice to match varied user needs.

LM5000 Delta – redefining value

New Holland LM5000 models are designed to suit all the needs of the modern farmer carrying out all types of work including bale, fertilizer and grain handling to name but a few. Powered by 120hp(CV) engines, drive is efficiently supplied through a four-speed 40kph Powershuttle transmission whilst a powerful gear pump and easy to use multifunction joystick make light work of all hydraulic requirements. Comfort is assured for operators of all sizes in the fully glazed and quiet 360° Vision cab. Forward thinking design allows options, such as air conditioning and rear hydraulic outlets to be fitted. LM5000 Delta. Entry level economy. Premium performance

LM5000 Plus - Specified to give you even more

The New Holland LM5000 Plus is more than capable of carrying out the general daily tasks of a demanding farm making light work of transport duties, muck handling and silage clamps where a high tear out force and fast operating cycles are a priority. Plus models have the hydraulic muscle to deliver outstanding performance. Sharing the same 120hp(CV) power unit of the Delta models, LM5000 Plus can be specified with either a four-speed 40kph Powershuttle or PowerShift™ transmission. The Powershift™ transmission allows the operator to shift between ratios quickly, and is well suited to applications that can include road work, loading bales in the field and fast re-handling. LM5000 Plus. Everything you need as standard.



Package Models	Delta			Plus		
	LM5040	LM5060	LM5080	LM5040	LM5060	LM5080
Max. power ISO 14396 - ECE R120 @ 2200 rpm [kW/hp(CV)]	88/120			88/120		
Max. lift height (m)	6.1	7.1	9.6	6.1	7.1	9.6
Max. lift capacity (kg)	3500	4000	3300	3500	4000	3300
Hydraulic pump type	Gear Pump			Gear Pump / Variable Pump		
Hydraulic flow (lpm)	130			130 / 145		
Hydraulic controls	Multi Function Joystick			Multi Function Proportional Joystick		
Transmission	Powershuttle			Powershuttle / PowerShift™		

MORE PRODUCTIVITY AND POWER.



All LM5000 models offer greater engine power and torque, increased capacity, greater lift heights and a hydraulic performance, superior to their like for like rear-engine predecessors. These increases can be fully exploited thanks to a combination of unique New Holland LM5000 design features. These include the patented driveline and corner-to-corner wheelbase chassis to ensure the extra engine power and enhanced lift and reach capacities provide genuine productivity benefits to the end user.

26% more power. 32% more torque. 22% more capacity

Power is increased from 95hp(CV) to 120hp(CV) and torque climbs massively from 398Nm to 525Nm when compared to previous generation New Holland telehandlers. Taking the LM5060 model as an example, the lift capacity climbs from 3.1 tonnes to 4.0 tonnes and lift heights rise from 6.8m to 7.1m. New Holland has completely redesigned the hydraulic system on LM5000 telehandlers to increase power and reduce operating temperatures. Larger rams are fitted to exploit the higher oil flow, with more power available to lift and extend the telescopic boom. Even the basic specification includes load sensing and flow sharing proportional functionality.

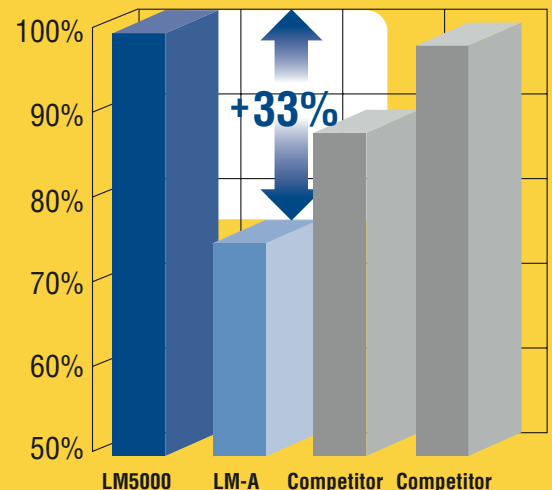

Up to 33% better capacity / reach index

The capacity/reach index on the new LM5000 telehandlers has increased by up to 33% versus its predecessor models. This will allow you to carry-out more demanding tasks with a more compact machine.

Turning performance into productivity

New Holland engineers have long recognised that improving telehandler productivity calls for more than just increasing engine power and hydraulic performance. Other factors, including manoeuvrability, visibility and stability all play critical roles in ensuring the operator can fully exploit the potential of the machine.

SUPERIOR VISIBILITY AND COMFORT.



When designing the LM5000 telehandler series, New Holland engineers started with the cab design. Based on dealer and customer feedback and product clinics, operator comfort remains a key design priority, with research continuing to support the view that a comfortable operator is a productive operator.

The 360° Vision cab has a number of features that set it apart from the competition. Featuring a fully glazed door and offering excellent visibility not just over the right three-quarters of the machine but also to the front and sides, the wide cab has a class leading internal volume.

Brilliant comfort

It is the small details that make LM5000 Delta and Plus models so comfortable to operate. From the wide and easy access through to the ability to see all round the machine when working, the 360° Vision cab offers more room, visibility and comfort. To add comfort for road work an optional smooth ride control boom suspension can be fitted. All models are fitted with a light and easy to operate multi-function joystick that is integrated in the arm rest to proportionally control the main raise/lower and tilt/crowd functions. Units Specified with the multi-function proportional joystick have the added advantage of proportional extend and retract control. The cab is mounted on isolation blocks which, when combined with the three-point engine and transmission vibration damping system makes for a quiet 74dBA and vibration free working environment. The high airflow ventilation or optional air conditioning systems are designed to provide warmth in winter and cooling in summer.

 Predecessor Model.
 LM5000.



Brilliant visibility - Up to 113% less "blind spot"

A number of design features are combined to give an LM5000 operator the excellent all-round visibility. The boom has a low pivot height and the way in which the bodywork and fenders are styled all help the operator see more. The spacious cab allows a relatively high seating position too, further increasing visibility to the front. Measurements have shown that blind spot area is up to 113% less on the new LM5000 models versus its predecessor models.



PROVEN QUALITY AND RELIABILITY.

New Holland LM5000 telehandlers are designed to offer more than just exceptional performance. Product quality and dependability has been designed in. To further boost dependability, these exceptionally efficient handlers benefit from the use of many proven components. The high performance Tier III engines are from the same family that power established New Holland tractors, including the outstanding T6000 series. The axles, brakes and transmissions are based on designs used in existing New Holland telehandlers, industrial loaders and backhoes. The hydraulic system is built around a reduced pressure, high flow concept proven to help reduce operating temperatures. The strong boom and corner-to-corner wheelbase chassis have been subjected to pre-production stress analysis and extensive operational and end user testing.

Cool running engine and transmission

Compared to existing New Holland rear-engine models, LM5000 cooling capacity is increased by a massive amount; up to two times more for the transmission and half as much again for the engine. The engine hood vent system allows cool air to be drawn in and hot air to be expelled extremely efficiently, ensuring cooling capacity is maintained from dawn to dusk.

Cool running hydraulics

New Holland has completely redesigned the hydraulic system on LM5000 telehandlers. The key aim has been to ensure the hydraulics retain optimum efficiency over extended operating periods and at high ambient temperatures. This has been achieved by lowering the operating system pressure, increasing hydraulic pump flow rates and fitting large hydraulic rams. Cooling capacity is increased at least fourfold when compared to the outgoing New Holland rear engine models.

Tested at every stage

New Holland test programmes are ongoing. Operator feedback from all markets is constantly reviewed to ensure LM5000 telehandlers deliver dependable performance in all applications and operating conditions. Every machine is checked at the end of the production line and prior to delivery to the end user.



LESS MAINTENANCE, MORE WORK.



New Holland is constantly striving to reduce maintenance demands across its entire product range with extended service intervals to reduce whole life operating costs. LM5000 telehandlers benefit from this work, with service intervals that are among the longest in their class. The LM5000 telehandlers benefit from 45% less maintenance cost over 2000 hours* versus predecessor models.

*Subject to the use of recommended lubricants and hydraulic oils and the exclusive use of New Holland filters and service parts.



Room to reduce your operating costs

The engine bay of LM5000 telehandlers provides generous service access to the engine and hydraulics. This makes servicing easier and less time consuming. These are critical factors in cutting downtime and costs. In addition the new LM5000 offers exceptional value for money.

SPECIFICATIONS.

DIMENSIONS

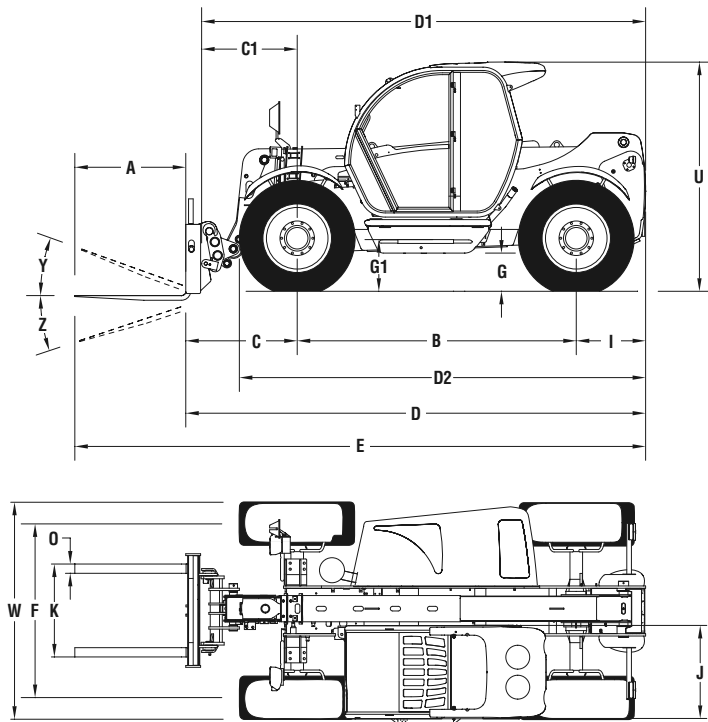

Models		LM5040	LM5060	LM5080
A Pallet Fork Length	(mm)	1200	1200	1200
B Wheel Base	(mm)	3010	3010	3010
C Axle to fork heel	(mm)	1202	1365	1497
C1 Axle to carrier	(mm)	1031	1196	1326
D Length fork heel to counter weight	(mm)	4960	5123	5255
D1 Length carrier to counter weight	(mm)	4789	4954	5084
D2 Length front tyre to counter weight	(mm)	4382	4382	4382
E Overall length	(mm)	6157	6322	6452
F Wheel track	(mm)	1873	1873	1873
G Ground Clearance	(mm)	420	420	420
G1 Clearance under step	(mm)	550	550	550
I Length rear axle to counter weight	(mm)	748	748	748
J Cab width	(mm)	1003	1003	1003
K Maximum fork spacing	(mm)	1185	1185	1185
O Fork section	(mm)	100x50	100x50	100x50
U Cab height	(mm)	2471	2471	2471
W Overall width (outside tyres)	(mm)	2340	2340	2340
Y Attachment roll back angle	(°)	26	26	26
Z Attachment dump angle	(°)	132	132	132
Total rotation angle (Y+Z)	(°)	158	158	158
Turning radius tyres	(mm)	3400	3400	3400
Total weight with forks, full fuel tank and driver	(kg)	7310	7510	8170

TECHNICAL DATA

Package Models		Delta			Plus		
		LM5040	LM5060	LM5080	LM5040	LM5060	LM5080
Max. lift capacity	(kg)	3500	4000	3300	3500	4000	3300
Max. lift height	(m)	6.1	7.1	9.6	6.1	7.1	9.6
Engine							
Biodiesel Approved		B100					
Type		4 Cylinder NEF, Tier III					
Displacement	(cm ³)	4485					
Aspiration		Turbo intercooler					
Max. power ISO 14396 - ECE R120 @ 2200 rpm	[kW/hp(CV)]	88/120					
Max. torque ISO 14396 - ECE R120 @ 1400 rpm	(Nm)	525					
Transmission							
Powershuttle	(4x4)	●	●	●	○	○	○
PowerShift™	(4x3)	-	-	-	●	●	●
Brakes							
Actuation		Hydraulic power assist					
All four wheels		Standard					
Type		Oil immersed discs					
Discs per axle		8					
Axles							
4WD		Permanent 4WD					
Differential lock	(Front / Rear)	Limited slip / locking					
Capacities							
Hydraulic oil	(l)	95					
Fuel	(l)	130					
Hydraulics							
Gear pump	(lpm/bar)	130/245	130/245	130/245	130/245	130/245	130/245
Variable pump	(lpm/bar)	-	-	-	145/245	145/245	145/245
Hydraulic controls		Multi Function Joystick			Multi Function Proportional Joystick		
Cab							
Seat		Mechanical adjustable suspension seat with joystick armrest					
Max noise level	(dBA)	74					
Vision	(°)	360					
Ventilation		Heater / Blower			Air Conditioning		
Adjustable steering column		●					
Split door		●					
Power steering modes		2WS / 4WS / Crab					
Wheels & Tyres							
Standard		460/70 R24					
Optional		405/70 R24					
Optional		400/80 R24					
Optional		19.5" R24					
Reversible Alarm / Beacon		●					
Safe Load Indicator		●					

● Standard ○ Optional - Not available

LOAD CHARTS

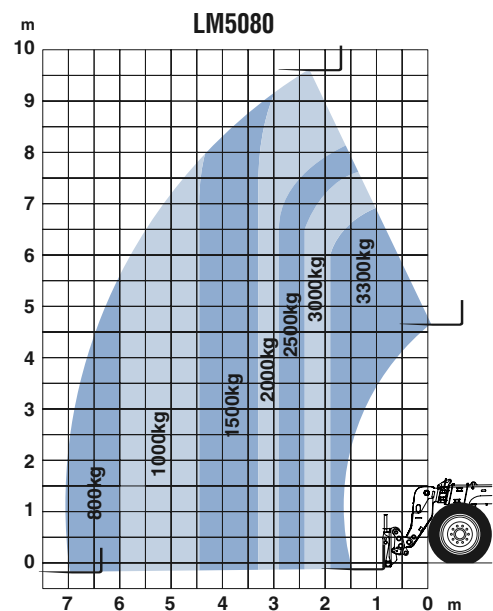
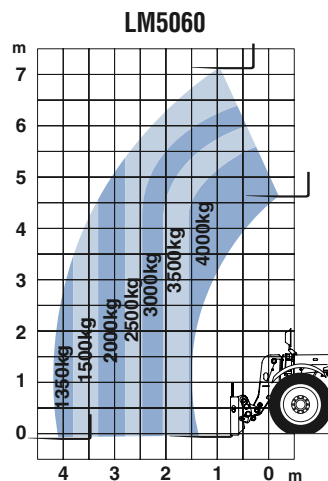
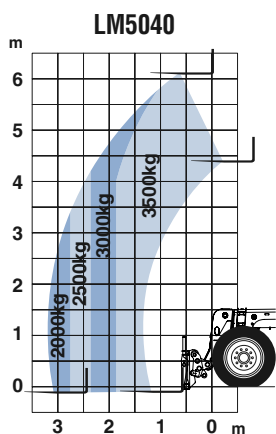

Managed in close partnership with New Holland dealers and New Holland Parts and Service Teams, New Holland Top Service is:



TOP AVAILABILITY.

We are always there for you: 24/7, all year round! Whatever information you need, whatever your problem or request, all you have to do is call the New Holland Top Service toll free number.



TOP SPEED.

Express parts delivery: when you need it, where you need it!



TOP PRIORITY.

Fast-track solution during the season: because your harvest can't wait!



TOP SATISFACTION.

We drive and track the solution you need, keeping you informed: until you are 100% satisfied!

 **TOP SERVICE**
00800 64 111 111

For more details, ask your New Holland dealer!



Your success - Our specialty

Visit our web site or call free phone number for UK: www.newholland.com/uk - tel: 0800 015 0105
for ROI: www.newholland.com/ie - tel: 1 800 523 174

The data indicated in this folder are approximate. The models described here can be subjected to modifications without any notice by the manufacturer. The drawings and photos may refer to equipment that is either optional or intended for other countries. Please apply to our Sales Network for any further information. Published by New Holland Brand Communications. Bts Adv. - Printed in Italy - 10/07 - TP01 - (Turin)



71000/INB

AT YOUR OWN DEALER

ASK FOR A TEST DRIVE!

New Holland prefers  lubricants